

Optimization of Energy Harvesting in Mobile Wireless Sensor Networks

Amin Al Ka'bi

Australian College of Kuwait, Kuwait

Email: a.kabi@ack.edu.kw

Abstract—The restricted availability of energy supplies is one of the major challenges in designing mobile wireless sensor networks. In this research work, a proposed method for extending the lifetime of energy-constrained mobile wireless sensor networks (MWSNs) is presented. This method is based on the fact that RF signal carries both information and energy at the same time. Hence, by increasing the efficiency of energy harvesting from radio frequency (RF) signals, the lifetime of the wireless network can be significantly extended. The Simultaneous Wireless Information and Power Transfer (SWIPT) technique enables harvesting of energy by relay nodes which in turn can be used for wireless data transmission. To enhance the lifetime of the mobile wireless network, the transmitted RF energy can be recycled at the receiver side. On the other hand, a balance between energy harvesting and wireless data transmission is required in to maximize the overall efficiency of the system. Particle Swarm Optimization (PSO) is employed to obtain the optimum resource allocation policy which maximizes the system energy efficiency. A cost function is framed for this purpose and PSO attains the maximum energy efficiency by improving the solution of the cost function at each iteration with respect to given constraints.

Index Terms - Simultaneous Wireless Information and Power Transfer (SWIPT); Energy Efficiency; Resource Allocation; Low Energy Adaptive Clustering Hierarchy (LEACH); Particle Swarm Optimization (PSO)

I. INTRODUCTION

The wireless sensors (nodes), which are powered by cells with limited energy, have restricted the lifetime of a wireless sensor network. This is an existing basic issue being faced by sensor networks which are used for long-haul tasks. Energy conservation techniques can only reduce the total energy consumption of the system but cannot compensate for the energy depletion. Deploying more nodes is undesirable as the deserted nodes may cause pollution to the surrounding environment. Replacing the cell or node is only applicable in cases in which the nodes can be located and physically accessed by humans or robots [1]-[4].

Wireless charging technology is a promising solution for addressing the energy limitations in sensor networks. The wireless charging technology, along with more cheap mobile robots, makes the power restoring process possible and controllable, and hence the power can be restored to satisfy energy requirements. Close alignment

between the charger and nodes is not required when compared to the node or cell replacement techniques.

Wireless charging technologies can be classified into two groups, which are Radio Frequency (RF) based wireless charging (radiative) and coupling-based wireless charging (non-radiative). RF waves are used as the medium for transferring energy in the case of radiative wireless charging. Here the transfer of energy is on the basis of the radiative electric field of the RF wave. Non-radiative wireless charging is commonly utilized in appliances of daily use due to safety considerations [5]-[7].

As the RF signal consists of both information and energy, it is considered as a promising method for wireless energy transfer where it enables simultaneous wireless information transfer along with energy harvesting. To improve the lifetime of the sensor network, the transmitted RF energy can be recycled at the receiver side. This technique is referred to as Simultaneous Wireless Information and Power Transfer (SWIPT) [8].

In this case, a data transmitting node transfers the energy together with the data to its cluster head. Based on Dynamic Power Splitting Scheme, the cluster head divides the received RF signals into two power streams with specific power splitting ratios for data forwarding and energy harvesting, respectively. This method has two merits: (a) harvesting energy from the RF transmitters, using the harvested energy in data forwarding, and hence avoiding the depletion of energy; (b) to improve the Quality-of-Service (QoS), energy may be harvested from either interference signals or RF signals of transmitters, and even antenna noises.

This work focuses on implementing an efficient resource allocation using particle swarm optimization with the aim of maximizing energy efficiency.

II. SYSTEM MODEL AND PROBLEM FORMULATION

A. System Model

The system model of the mobile WSN consists of a mobile collector and N nodes. The sensor network consists of antennas randomly distributed over the field under consideration. Periodically, a deployed mobile collector conducts an information gathering tour beginning from the sink node. At each tour in the field, it visits some previously determined anchor nodes, known as cluster heads for collecting information from the

neighboring sensors through multiple hop transmission by staying near them for a specific period of time. On the basis of a clustering protocol known as Low Energy Adaptive Clustering Hierarchy (LEACH) [9]-[11], the sensor nodes are grouped as clusters before starting the information gathering tour. In this case, each cluster consists of a cluster head (CH) for collecting the information sensed by each sensor in its cluster through relays of other nodes. This collected information is then uploaded to the mobile collector, as illustrated in Fig. 1. The cluster heads also act as anchors for the data collector. The nodes transmit their sensed information to the CHs including the energy. The RF energy is also harvested from the data received by the CH and then the data is aggregated. A CH consists of a signal processing unit with a rechargeable cell, an energy harvesting unit, and a power splitting unit to maintain simultaneous data forwarding and energy harvesting, as depicted in Fig. 2. The circuit in the receiver designed for data forwarding cannot be used for energy harvesting because of hardware limitations [1]. Consequently, the energy harvesting unit and the data processing unit should have separate circuitries.

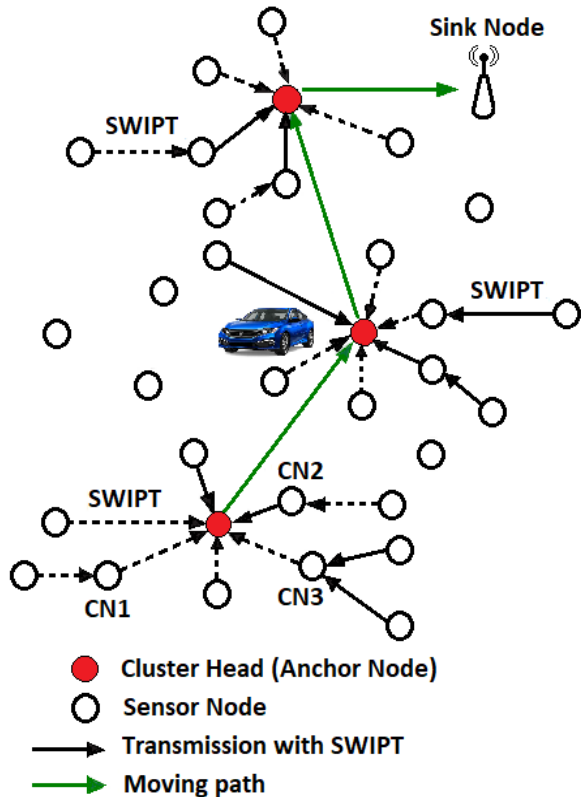

Fig. 1. SWIPT in a 3 cluster WSN.

At the transmitter side, time-slotted transmission is employed, and at the receiver side a dynamic power splitting scheme is employed, which enables the receiver to process the data and energy harvesting from the received signal at any instant. The basic principle behind this technique is illustrated in Fig. 2. The received signal from transmitter of the i^{th} node is split dynamically by the receiver at the j^{th} CH into two energy streams for

data processing and energy harvesting in ratios ρ_i^I and ρ_i^E respectively.

The transmitting nodes are grouped into clusters such that the cluster heads lie within the effective coverage area of the transmitting antennas, then by using an efficient power management circuit, the received power is converted to DC using AC/DC converter, and then this power is transferred to the storage cell to power a sensor. The energy harvested in the cell helps in lowering the minimum power transfer requirement $Q_{req\ min\ i\ j}$, and hence further limits the power splitting ratio for harvesting energy, thereby enhancing the rate of data transmission in the wireless network. The power splitting unit is assumed as perfect [1], and hence, it will not lead to any power loss or noise. The power consumed by each node is fixed as P_c Watts for processing a unit of data and does not depend on the amount of energy harvested. And hence, when the data processing rate of a sensor is R , the total power consumption of the circuit is $P_c * R$ Watts. Hence, powering the CHs by more than one energy source is practically desirable [12].

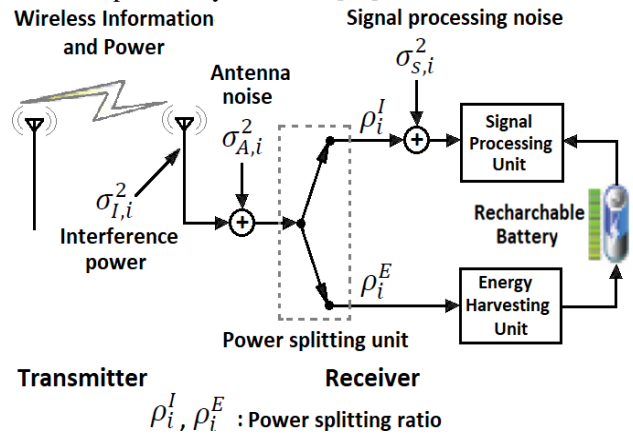

Fig. 2. Model of a receiver with SWIPT.

B. Communication Model

The communication model of the wireless sensor network consists of clusters of sensors. Let us assume that one of these clusters consists of a CH and $N-1$ sensors, represented as $N = \{N_1, N_2, \dots, N_{N-1}\}$, which are grouped using LEACH algorithm. The directed graph of this sensor network is then modelled as $X = (M, C)$; $M = N \cup CH$ is the group of all nodes, and C corresponds to the group of all connected links between the sensors and the CH. The condition for a connected link $(i, j) \in C$ to exist is that $d_{ij} \leq r_{tx}$ where d_{ij} indicates the distance between i^{th} node and j^{th} node, r_{tx} denotes the transmission range of the sensors, which depends on the transmitted power and gain of the sensor. The channel between transmitter and the receiver is assumed to be that of a quasi-static block fading model. The channel gains are calculated by obtaining the receiver feedback. As depicted in Fig. 2, the corruption of the received signal occurs due to an Additive White Gaussian Noise generated from the sensor at the receiver. Then the received RF signal is then delivered to a power splitting

unit, at which it is split and then separately fed to the energy harvesting unit and the information processing unit.

The capacity of the channel across the i^{th} transmitter and j^{th} receiver can be calculated as

$$C = W \log_2(1 + P_{ij} \gamma_{ij} \rho_{ij}^l) \quad (1)$$

where W denotes the band-width and P_{ij} denotes the transmitted power from the i^{th} transmitter to j^{th} receiver, and γ_{ij} denotes the channel path loss due to attenuation, shadowing, and other path losses. The maximum data rate R_{ij} that can be achieved in the case of reliable data forwarding from the i^{th} transmitter to j^{th} receiver is always less than channel capacity C_{ij} between them, i.e.,

$$R_{ij} < W \log_2(1 + P_{ij} \gamma_{ij} \rho_{ij}^l) \quad (2)$$

In the case of transfer of energy, according to the rule of energy conservation, the energy received by the receiving antenna is always less than the harvested energy denoted by Q_{Dij} Joules.

$$Q_{Dij} \leq P_{ij} \xi_{ij} \rho_{ij}^E n_{ij} \quad (3)$$

where $0 < \xi_{ij} < 1$ represents the coefficient for harvesting energy from i^{th} transmitter by j^{th} receiver which implies that the entire energy radiated by i^{th} transmitter is not harvested by j^{th} receiver. $0 < n_{ij} < 1$ shows the efficiency of energy conversion of j^{th} receiver in conversion of the received RF signal into electrical energy for storing in the cell, which is dependent upon the process of rectification used and the circuit used for harvesting energy [3]. Maximum values are assumed to R_{ij} and Q_{Dij} , i.e., the two sides of the inequalities in (2) and (3) become equal.

C. Problem Formulation

The resource allocation problem is formulated such that it maximizes the system energy efficiency (Bit/J).

1) End-to-End data throughput

The total number of bits conveyed to receivers successfully per second is known as the end-to-end data throughput.

$$F(P, \rho) = \sum_{i,j=1}^N \alpha_{ij} W \log_2(1 + P_{ij} \gamma_{ij} \rho_{ij}^l) \quad (4)$$

In which $P = \{P_{ij} \geq 0, \forall i, j \in M\}$ represents the policy for power allocation, ρ_{ij} is the policy for power splitting. To ensure a particular degree of fairness, the application layer fixes α_{ij} which is a positive weight accounting for the priorities of different receivers. To improve the system energy efficiency, the overall system energy consumption is considered. The weighted energy consumed by the system $F_{EC}(R, P, \rho)$ needed for reliable communication is modelled as the total power dissipation, which is given by

$$F_{EC}(R, P, \rho) = \sum_{i,j=1}^N P_{ij} R_{ij} + \sum_{i,j=1}^N \varepsilon P_{ij} \quad (5)$$

where, $\varepsilon \geq 1$ is a constant accounting for the inefficiency of the transmitter, and R_{ij} represents the data rate.

2) Efficiency of energy harvesting

The sum of the weighted number of bits delivered successfully to the receivers per one Joule of consumed energy is called as the weighted energy efficiency of the system and it can be expressed as

$$F_{eff}(R, P, \rho) = F(P, \rho) / F_{EC}(R, P, \rho) \quad (6)$$

The resource allocation problem (ResAll) is then formulated into a nonlinear optimization problem:

$$\max_{R,P,\rho} [F_{eff}(R, P, \rho)] \quad (7)$$

which is subjected to

$$C1: Q_{Dij} + Q_{Iij} \geq Q_{min}^{req} \quad (8)$$

$$C2: R_{min\ ij} \leq R_{ij} \leq C_{ij} \quad (9)$$

$$C3: \sum_{i,j=1}^N \alpha_{ij} W \log_2(1 + P_{ij} \gamma_{ij} \rho_{ij}^l) \geq R_{min} \quad (10)$$

$$C4: P_{ij}^{min} \leq P_{ij} \leq P_{ij}^{max} \quad (11)$$

$$C5: \rho_{min}^E \leq \rho_{ij}^E \leq \rho_{max}^E \quad (12)$$

$$C6: \rho_{min}^l \leq \rho_{ij}^l \leq \rho_{max}^l \quad (13)$$

$$C7: \rho_{ij}^E + \rho_{ij}^l \leq 1 \quad (14)$$

in which C1 is the minimum power transfer requirement $Q_{req\ min\ ij}$ for power transfer from j^{th} receiver to i^{th} transmitter. It shows that the energy harvested is invalid in the case when the energy harvested is lesser than the energy consumed by the circuit for harvesting energy. C2 shows the minimum individual data transfer rate $R_{min\ ij}$ from i^{th} transmitter to j^{th} receiver and it is always less than the channel capacity. C3 indicates the Quality-of-Service constraint of the system, which specifies that the total end-to-end throughput must be greater than the minimum value of the data rate of the system, R_{min} . C4 specifies the constraint for a power transmission which shows that the harvesting energy circuit is capable of operating in the case when the RF incident power is greater than the threshold P_{ij}^{min} , and less than the maximum transmitted power P_{ij}^{max} , whose value is dependent on the hardware limitations of the power amplifier. A threshold is required for triggering the charge pump in the circuit for harvesting energy and is specified in C4. C5 - C7 represent the constraints for power splitting. C5 indicates that the ratio of power splitting for energy harvesting is bounded by the lower limit ρ_{min}^E and upper limit ρ_{max}^E . C6 represents the lower

limit and upper limits of the power splitting ratio for data processing, i.e., ρ_{min}^l and ρ_{max}^l respectively, where $\rho_{min}^E + \rho_{max}^l = 1$, and $\rho_{max}^E + \rho_{min}^l = 1$. Power splitting constraint is specified in C7, which shows the passiveness of the power splitting unit, and hence no power gain can be attained by this process of power splitting.

The theoretical model is practically suitable for optimization for any node, including the CH node, in the case when 2 nodes which are inter-connected and are able to transmit data. Additionally, on the basis of Quality-of-Service requirements of each node and the system $R_{min ij}$ and R_{min} are selected in such a way that helps in attaining a trade-off between system energy efficiency and the total system capacity. As the value of R_{min} increases, the transmit power has to be increased to satisfy the requirement of greater data rate by reducing the energy efficiency of the system. Then, based on the ability of the receiver in dividing the received power, the values of ρ_{min}^E and upper limit ρ_{max}^E are selected.

To maximize the aggregated energy efficiency of all sensor nodes, the objective function (7) is used. By using this function, the policy for data rate control R^* , policy for power splitting ρ^* , and policy for power allocation P^* is obtained.

III. SOLUTION OF THE OPTIMIZATION PROBLEM

The resource allocation problem is solved using two methods, i.e., Resource Allocation Algorithm (ResAll) [1] and Particle Swarm Optimization (PSO) [2].

A. ResAll Algorithm

The ResAll algorithm is based on the iterative Dinkelback method [13]. Using this algorithm, resource allocation policies are determined.

Input:

- i - index of iteration;
- I_{max} - maximum number of iterations;
- n - system energy efficiency;
- e - an infinitesimal number;

Output:

- n^* - maximum energy efficiency;
- $\{R^*, P^*, \rho^*\}$ - resource allocation policies;

```

i = 1, n = 0;
for ( i ≤ I_max )
{
if ( F(P, ρ) - nF_EC(R, P, ρ) < e
return {R*, P*, ρ*} = {R, P, ρ}
n* = F(P, ρ)/F_EC(R, P, ρ)
else
Set n = F(P, ρ)/F_EC(R, P, ρ)
i = i + 1
}
end
    
```

This algorithm provides resource allocation policy which maximizes the energy efficiency This efficiency is

further increased by solving the optimization problem using Particle swarm optimization (PSO) [2]. Optimum resource allocation policies are obtained using PSO.

B. Particle Swarm Optimization

Particle swarm optimization (PSO) is a computational method in which optimization is done by trying to improve a candidate solution problem at each iteration with respect to a given measure of quality. It is a population-based method. Here the population of candidate solutions are known as particles. The objective of PSO is to find a solution for a constrained minimization problem based on a particular cost function. Here the state of the algorithm is represented by a population, which varies in each iteration until some criterion is met. Here, the population $P = \{p_1, p_1, \dots, p_n\}$ is the set of feasible solutions and is referred to as swarm. These feasible solutions p_1, p_1, \dots, p_n are referred to as particles, given by $p_i = (P_i, R_i, \rho_i); i = \{1, 2, \dots, n\}$. A set of feasible solutions is considered as the search space in which these particles move. The number of particles generally selected is between 10 and 50 in practical for solving optimization problems.

The population is not changed from generation to generation in PSOs, instead, the same population is maintained by updating the particle positions at each. In PSOs, the particles “interact” or “influence” each other.

$x_i(t)$... the position vector.

$p_i(t)$... the ‘historical’ best position.

$l_i(t)$... the historical best position of the i^{th} neighboring particle; it represents the historical best-known position of the entire swarm in the case of fully connected topology.

$v_i(t)$... the velocity; i.e., the step size across $x_i(t)$ and $x_i(t + 1)$.

When the algorithm starts, the initial velocities are set to 0, or to some small random values, and the initial particle positions are selected in a random manner.

PSO parameters:

In this algorithm, $w(t)$ represents the damping factor known as inertia weight whose value decreases from around 0.9 to around 0.4 during computation.

c_1, c_2 represent the acceleration coefficients. In general, they have values between 0 and 4.

The velocity of the particle is updated as per the equation

$$v_i(t + 1) = c_1 u_1 (p_i(t) - x_i(t)) + c_2 u_2 (l_i(t) - x_i(t)) + w(t) v_i(t) \quad (15)$$

where u_1 and u_2 represent random variables according to the uniform distribution $U(0,1)$. The first term of Eq. (15) is known as the personal component, the middle term represents the mutual component, and the last one represents the inertia term.

The i^{th} particle position is updated based on the equation:

$$x_i(t + 1) = \int [v_i(t + 1) + v_i(t)]dt \quad (16)$$

The termination of this algorithm either occurs once the fitness value of the particles in the population become close enough, or when a maximum number of iterations is reached based on a given cost function. The cost function Z can be expressed as

$$Z = 1/F_{eff}(R, P, \rho) \quad (17)$$

Subjected to constraints C1 to C7.

By using this cost function, the optimization problem can be solved by using PSO to find the optimum resource allocation policies (R^*, P^*, ρ^*) , and hence maximizing the energy efficiency [14]-[17].

IV. SIMULATION RESULTS

The simulation results using MATLAB v2018b are discussed here. The simulation settings for ResAll and PSO are shown in Table I and Table II, respectively.

TABLE I. SIMULATION SETTINGS FOR RESALL

Parameter	Values
W	200Mbps
ϵ	0.02
P_{ij}^{min}	0.3dBm
R_{min}	50 Mbps

TABLE II. SIMULATION SETTINGS FOR PSO

Parameter	Values
w	1
c_1	1.5
c_2	2

Nodes are clustered using LEACH (Low Energy Adaptive Clustering Hierarchy) algorithm, where one hundred nodes are randomly selected and deployed in an 100m×100m area. Position of the sink node is fixed at (50,50). Each node has an initial energy E_0 of 0.5J.

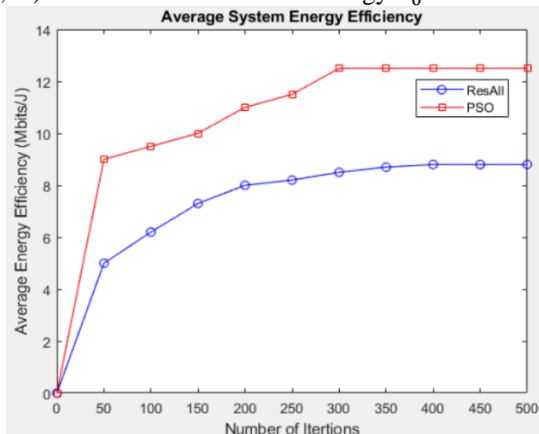

Fig. 3. Energy efficiency vs. number of iterations.

Fig. 3 shows a comparison of the energy efficiency vs. the number of iterations of ResAll and PSO algorithms. It can be seen in Fig. 3 that PSO provides more average energy efficiency compared to ResALL for a specified number of iterations. This is due to the improved solution of the cost function Z at each iteration with respect to the given constraints.

It can be seen that maximum energy efficiency of 12Mb/J is obtained by using PSO while 8M/J is obtained by using ResAll algorithm.

V. CONCLUSION

The ever-increasing ubiquitous applications of wireless sensor networks lead to energy scarcity in the network, which is a serious threat to the lifetime of the network. To solve this issue, here, Simultaneous Wireless Information and Power Transfer (SWIPT) technique is applied to a MWSN. The nodes were clustered using LEACH algorithm. A resource allocation algorithm is designed by considering the power splitting capabilities of relay nodes and cluster heads. Optimal Resource allocation policies are found out using particle swarm optimization.

In the proposed method, the received power is split into two sets of power streams using arbitrary power splitting ratios. By considering the various power splitting capabilities of receivers, a Resource Allocation (ResAll) algorithm is used to find the resource allocation policies.

In ResAll algorithm, system energy efficiency is achieved by balancing data rate, energy efficiency, power splitting ratio, and transmit power. Maximum system energy efficiency is achieved by balancing transmit power, data rate, power splitting ratio, and energy efficiency. This is achieved by framing a cost function and then improving the solution to the cost function at each iteration with respect to the constraints. Simulation result show that the energy efficiency is further increased by solving the resource allocation problem using particle swarm optimization.

CONFLICT OF INTEREST

The author declares no conflict of interest.

AUTHOR CONTRIBUTIONS

The paper has one author, and he approved the final version.

REFERENCES

- [1] S. Guo, Y. Shi, Y. Yang, B. Xiao, and F. Ye, "Energy efficiency maximization in mobile wireless energy harvesting sensor networks," *IEEE Transactions on Mobile Computing*, vol. 1, no. 2, pp. 86-91, 2017.
- [2] K. Huang and V. K. N. Lau, "Enabling wireless power transfer in cellular networks: Architecture, modeling and deployment," *IEEE Trans. Wireless Comm.*, vol. 13, no. 2, pp. 902-912, Feb. 2014.

- [3] J. Yang and H. Zhang, "Task allocation for wireless sensor network using modified binary particle swarm optimization," *IEEE Sensors Journal*, vol. 14 no. 3, pp. 882-892.
- [4] A. H. A. Ka'bi, "Effect of polarization on the performance of adaptive antenna arrays," *Journal of Communications*, vol. 15, no. 9, pp. 661-668, Sep. 2020.
- [5] A. A. Ka'bi and M. Rady, "A proposed model for frequency tuned antennas used in mobile communication systems," *International Journal of Electrical and Computer Engineering*, vol 11, no. 2, pp. 1367-1374, April 2021.
- [6] M. Zhao, J. Li, and Y. Yang, "A framework of joint mobile energy replenishment and data gathering in wireless rechargeable sensor networks," *IEEE Trans. Mobile Computing*, vol. 13, no. 12, pp. 2689-2705, 2014.
- [7] B. Tong, Z. Li, G. Wang, and W. Zhang, "How wireless power charging technology affects sensor network deployment and routing," *IEEE ICDCS*, 2010.
- [8] A. H. A. Ka'bi, "Comparison of energy simulation applications used in green building," *Annals of Telecommunications*, vol. 75, no. 7-8, pp. 271-290, August 2020.
- [9] R. Zhang and C. K. Ho, "MIMO broadcasting for simultaneous wireless information and power transfer," *IEEE Trans. Wireless Comm.*, vol. 12, no. 5, pp. 1989-2001, May 2013.
- [10] A. Al-Ka'bi, M. Bialkowski, and J. Homer, "Performance of adaptive array antennas in mobile fading environment," *Transactions of Circuits, Devices and Systems, Journal of Institution of Engineering and Technology*, vol. 2, no. 1, pp. 95-102, February 2008.
- [11] C. Wang, J. Li, F. Ye, and Y. Yang, "NETWRAP: An NDN based real-time wireless recharging framework for wireless sensor networks," *IEEE Trans. Mobile Computing*, vol. 13, no. 6, pp. 1283-1297, 2014.
- [12] Z. Li, Y. Peng, W. Zhang, and D. Qiao, "Leach protocol in wireless sensor network," in *Proc. IEEE 19th Int. Conf. Network Protocols*, 2011, pp. 373-382.
- [13] A. A. Ka'bi, "The effects of mutual coupling and polarization on the performance of steered-beam adaptive arrays," *Journal of Computational Electronics*, vol. 20, no. 1, pp. 458-466, Jan. 2021.
- [14] W. Dinkelbach, "On nonlinear fractional programming," *Manag. Science*, vol. 13, pp. 492-498, Mar. 1967.
- [15] A. H. A. Ka'bi, "Effect of polarization on the performance of adaptive antenna arrays," *Journal of Communications*, vol. 15, no. 9, pp. 661-668, September 2020.
- [16] K. Anusha and G. I. Shamini, "Power and resource allocation using modified binary particle swarm optimization in neural network," in *Proc. IEEE WiSPNET 2016 Conference*, 2016.
- [17] A. A. Ka'bi, "Performance of adaptive antennas in presence of polarized electromagnetic signals," *Telecommunications and Radio Engineering*, vol. 79, no. 4, pp. 291-304, May 2020.

Copyright © 2022 by the authors. This is an open access article distributed under the Creative Commons Attribution License ([CC BY-NC-ND 4.0](https://creativecommons.org/licenses/by-nc-nd/4.0/)), which permits use, distribution and reproduction in any medium, provided that the article is properly cited, the use is non-commercial and no modifications or adaptations are made.



Amin Al Ka'bi was born in Jordan. He received his B.Sc. and M.Sc. degrees from the University of Jordan in 1989 and 1992 respectively, majoring in Electrical Engineering. He got his Ph.D. from the University of Queensland, Australia in 2006 in the field of Electrical Engineering/ Communications.

He has long industrial and academic experience in reputable industrial and academic institutions before joining the Australian College of Kuwait as an Assistant Professor. His current research interests focus on wireless communication systems and signal processing.